

JVC

SERVICE MANUAL

DVD/CD RECEIVER

KD-DV5000

Area Suffix

E Continental Europe

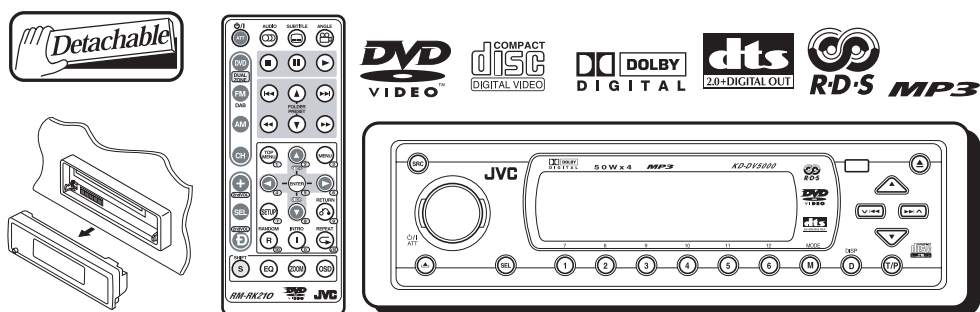

TABLE OF CONTENTS

1	PRECAUTION.....	1-3
2	SPECIFIC SERVICE INSTRUCTIONS.....	1-5
3	DISASSEMBLY.....	1-6
4	ADJUSTMENT.....	1-19
5	TROUBLE SHOOTING.....	1-23

SPECIFICATION

AUDIO AMPLIFIER SECTION	Maximum Power Output	Front	50 W per channel		
		Rear	50 W per channel		
	Continuous Power Output (RMS)	Front	19 W per channel into 4 Ω , 40 Hz to 20 000 Hz at no more than 0.8% total harmonic distortion.		
		Rear	19 W per channel into 4 Ω , 40 Hz to 20 000 Hz at no more than 0.8% total harmonic distortion. 0.8% total harmonic distortion.		
	Load Impedance	4 Ω (4 Ω to 8 Ω allowance)			
	Equalizer Control Range	Frequencies	60 Hz, 150 Hz, 400 Hz, 1 kHz, 2.4 kHz, 6 kHz, 12 kHz		
		Level	± 10 dB		
		Signal-to-Noise Ratio	70 dB		
		Audio output level			
		Analog (2nd AUDIO OUT)	6 mW (at 16 Ω)		
	Digital (DIGITAL OUT: Optical)	Signal wave length: 660 nm	Output level	-21 dBm to -15 dBm	
	Line-Out Level/Impedance	2.0 V/20 k Ω load (full scale)			
	Output Impedance	1 k Ω			
	Color system	NTSC			
Video output (composite)	1 Vp-p/75 Ω				
TUNER SECTION	Frequency Range	FM	87.5 MHz to 108.0 MHz		
		AM	(MW) 522 kHz to 1620 kHz (LW) 144 kHz to 279 kHz		
	[FM Tuner]	Usable Sensitivity	11.3 dBf (1.0 μ V/75 Ω)		
		50 dB Quieting Sensitivity	16.3 dBf (1.8 μ V/75 Ω)		
		Alternate Channel Selectivity (400 kHz)	65 dB		
		Frequency Response	40 Hz to 15000 Hz		
		Stereo Separation	35 dB		
		Capture Ratio	1.5 dB		
	[AM Tuner]	Sensitivity	20 μ V		
		Selectivity	35 dB		
DVD/CD PLAYER SECTION	Signal Detection System	Non-contact optical pickup (semiconductor laser)			
	Number of channels	2 channels (stereo)			
	Frequency Response	DVD, fs=48 kHz	16 Hz to 22000 Hz		
		DVD, fs=96 kHz	16 Hz to 44000 Hz		
	VCD, CD, MP3	16 Hz to 20000 Hz			
	Dynamic Range	96 dB			
	Signal-to-Noise Ratio	98 dB			
	Wow and Flutter	Less than measurable limit			
	MP3 recording format	MPEG 1/2 Audio Layer 3			
Max. Bit rate	320 Kbps				
GENERAL	Power Requirement	Operating Voltage:	DC 14.4 V (11 V to 16 V allowance)		
	Grounding System	Negative ground			
	Allowable Operating Temperature	0°C to +40°C (32°F to 104°F)			
	Dimensions (W \times H \times D)	Installation Size (approx.)	182 mm \times 52 mm \times 158 mm (7-3/16" \times 2-1/16" \times 6-1/4")		
		Panel Size (approx.)	188 mm \times 58 mm \times 12 mm (7-7/16" \times 2-5/16" \times 1/2")		
	Mass (approx.)	1.7 kg (3.8 lbs) (excluding accessories)			

- Design and specifications are subject to change without notice.
- If a kit is necessary for your car, consult a telephone directory for the nearest car audio speciality shop.
- Mistracking may result from driving on extremely rough roads. This does not damage the unit and the disc, but will be annoying. We recommend that you stop disc play while driving on such rough roads.

SECTION 1 PRECAUTION

1.1 Safety Precautions

 **CAUTION** Burrs formed during molding may be left over on some parts of the chassis. Therefore, pay attention to such burrs in the case of performing repair of this system.

 **CAUTION** Please use enough caution not to see the beam directly or touch it in case of an adjustment or operation check.

1.2 Preventing static electricity

Electrostatic discharge (ESD), which occurs when static electricity stored in the body, fabric, etc. is discharged, can destroy the laser diode in the traverse unit (optical pickup). Take care to prevent this when performing repairs.

1.2.1 Grounding to prevent damage by static electricity

Static electricity in the work area can destroy the optical pickup (laser diode) in devices such as mechanism unit.

Be careful to use proper grounding in the area where repairs are being performed.

(1) Ground the workbench

Ground the workbench by laying conductive material (such as a conductive sheet) or an iron plate over it before placing the traverse unit (optical pickup) on it.

(2) Ground yourself

Use an anti-static wrist strap to release any static electricity built up in your body.

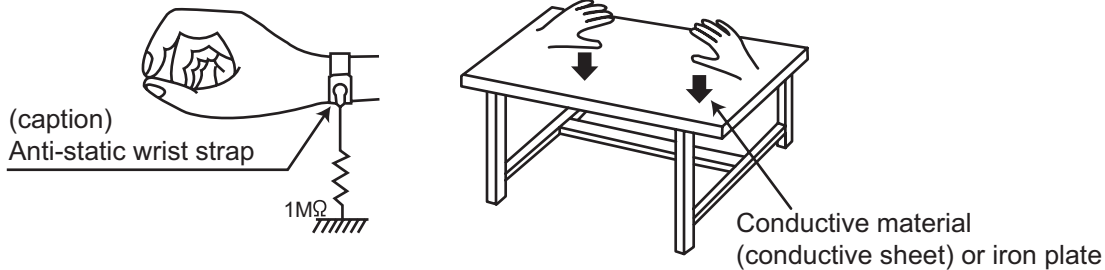

(3) Handling the optical pickup

- In order to maintain quality during transport and before installation, both sides of the laser diode on the replacement optical pickup are shorted. After replacement, return the shorted parts to their original condition. (Refer to the text.)
- Do not use a tester to check the condition of the laser diode in the optical pickup. The tester's internal power source can easily destroy the laser diode.

1.3 Handling the traverse unit (optical pickup)

- (1) Before disconnecting the flexible wire from the connector [CN10](#) on the front end board, solder the short-circuit point on the flexible wire.

Caution:

If you do not follow this instruction, the DVD pickup may be damaged.

- (2) Disconnect the flexible wire from the connector [CN10](#) on the front end board.
(3) Remove the solders from the short-circuit point on the flexible wire after replacing the DVD pickup.
(4) Connect the flexible wire to the connector [CN10](#) on the front end board.

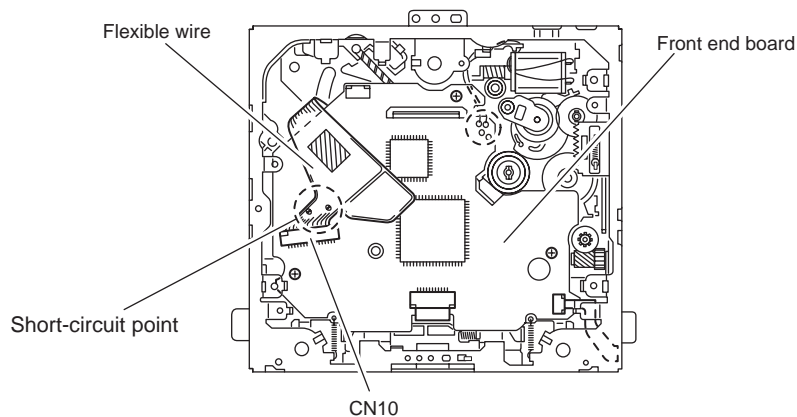

SECTION 2
SPECIFIC SERVICE INSTRUCTIONS

This service manual does not describe SPECIFIC SERVICE INSTRUCTIONS.

SECTION 3 DISASSEMBLY

3.1 Main body section

3.1.1 Removing the front panel assembly (See Fig.1)

- (1) Push the detach button in the lower left part of the front panel assembly and remove the front panel assembly.

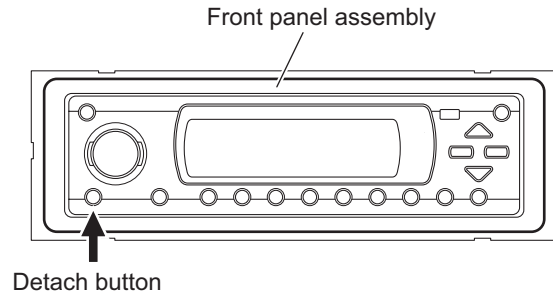

Fig.1

3.1.2 Removing the bottom cover (See Fig.2)

- Prior to performing the following procedures, remove the front panel assembly as required.
 - (1) Turn over the main body and remove the two screws **A** attaching the bottom cover.
 - (2) Release the two joints **a**, two joints **b** and joint **c**.

Caution:

Do not damage the main board when releasing the joints using a screwdriver or a similar tool.

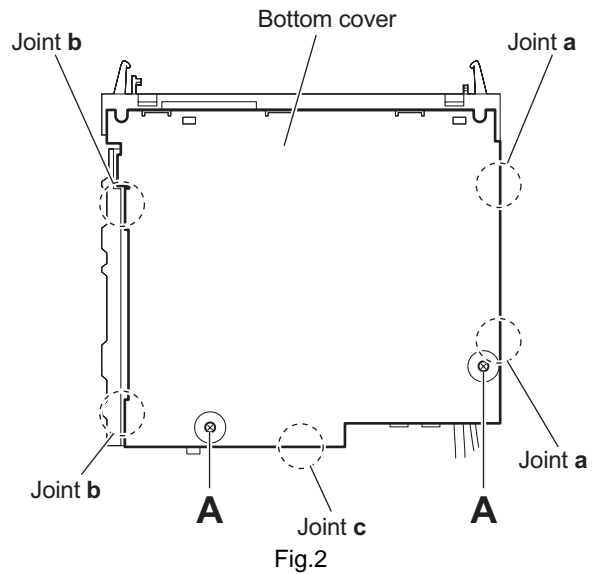

Fig.2

3.1.3 Removing the front chassis assembly (See Figs.3 and 4)

- Prior to performing the following procedures, remove the front panel assembly and bottom cover.
 - (1) From the both sides of the main body, remove the two screws **B** attaching the front chassis assembly. (See Fig.3.)
 - (2) From the front side of the main body, remove the two screws **C** attaching the front chassis assembly. (See Fig.4.)
 - (3) From the both sides of the main body, release the two joints **d** and two joints **e**. (See Fig.3.)

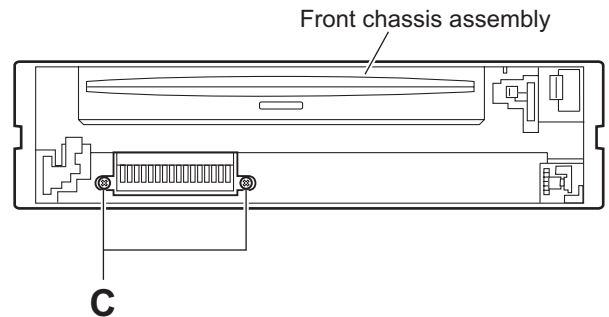
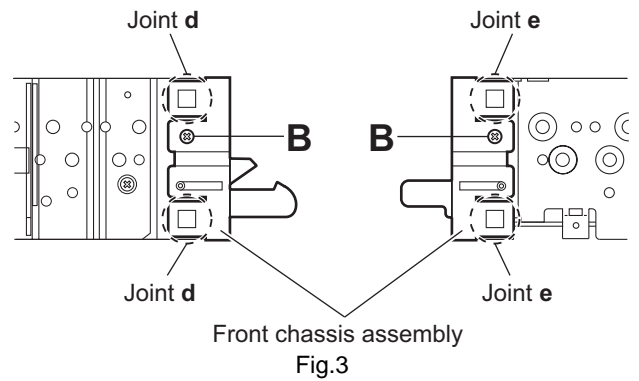

Fig.4

3.1.4 Removing the heat sink (See Fig.5)

- Prior to performing the following procedure, remove the front panel and front chassis assemblies as required.
 - (1) From the left side of the main body, remove the two screws **D** and three screws **E** attaching the heat sink.

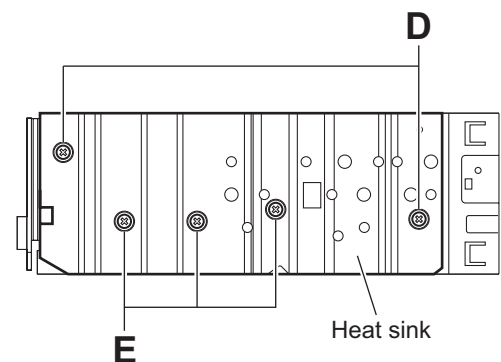

Fig.5

3.1.5 Removing the rear bracket (See Fig.6)

- Prior to performing the following procedures, remove the bottom cover.
 - (1) From the back side of the main body, remove the three screws **F**, five screws **G**, two screws **H**, screw **J**, screw **K** and screw **L** attaching the rear bracket.
 - (2) Remove the rear bracket.

Note:

When attaching the screws **K** and **L**, attach the AV cable and antenna cable holders with them.

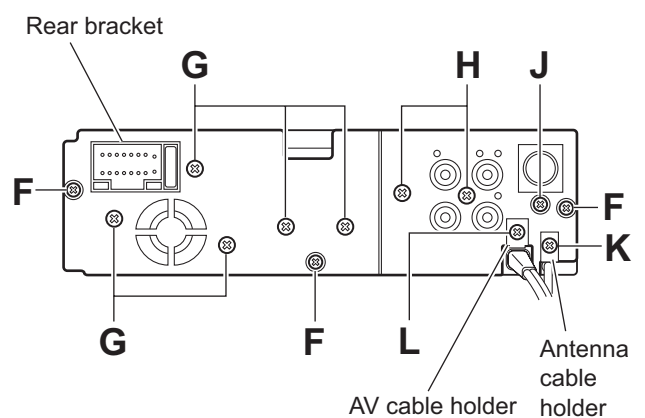

Fig.6

3.1.6 Removing the main board (See Fig.7)

- Prior to performing the following procedures, remove the front panel assembly, bottom cover, front chassis assembly, heat sink and rear bracket.

- (1) Remove the two screws **M** attaching the main board.
- (2) Disconnect the connectors [CN781](#) and [CN782](#) on the main board from the DVD mechanism assembly.

Reference:

- Remove the fan unit as required.
(Disconnect the fan unit wire from the connector [CN531](#) on the main board and remove the fan unit.)

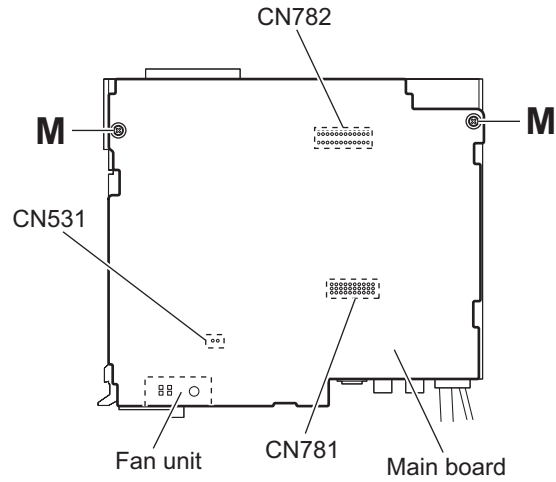

Fig.7

3.1.7 Removing the DVD mechanism assembly (See Fig.8)

- Prior to performing the following procedure, remove the front panel assembly, bottom cover, front chassis assembly, heat sink, rear bracket and main board.

- (1) From the inside of the top chassis, remove the three screws **N** attaching the DVD mechanism assembly.

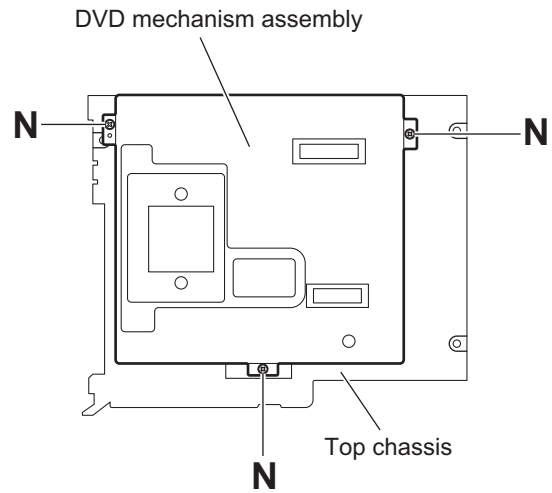

Fig.8

3.1.8 Removing the back end board (See Figs.9 to 11)

- Prior to performing the following procedures, remove the front panel assembly, bottom cover, front chassis assembly, heat sink, rear bracket, main board and DVD mechanism assembly.
 - (1) From the top side of the DVD mechanism assembly, remove the two screws **P** attaching the heat sink (MECHA). (See Fig.9.)
 - (2) Remove the two screws **Q** attaching the shield. (See Fig.9.)
 - (3) Remove the shield and heat sink (MECHA) from the DVD mechanism assembly.
 - (4) Remove the two screws **R** attaching the heat sink (P). (See Fig.10.)
 - (5) Release the two joints **f** and then release the two joints **g**. (See Fig.10.)
 - (6) Disconnect the card wire from the connector **CN506** on the back end board. (See Fig.10.)
 - (7) Remove the four screws **S** and screw **S'** attaching the back end board. (See Fig.10.)
 - (8) Release the three joints **h** and then take out the back end board from the DVD mechanism assembly. (See Fig.11.)

Reference:

When attaching the screw **S'**, attach the earth wire with it. (See Fig.11.)

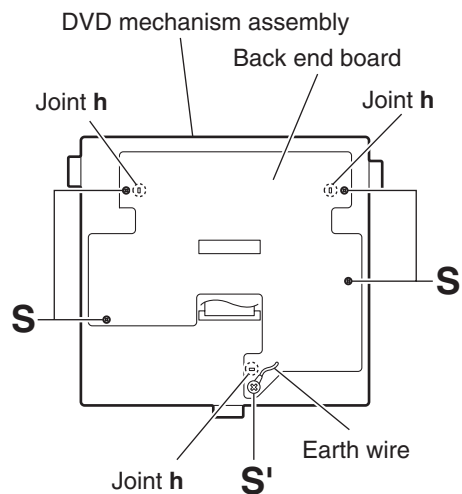
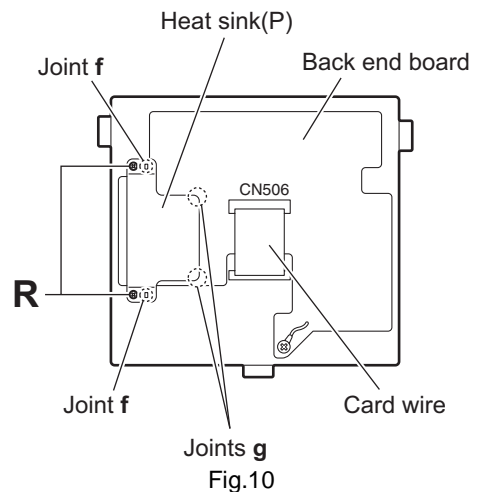
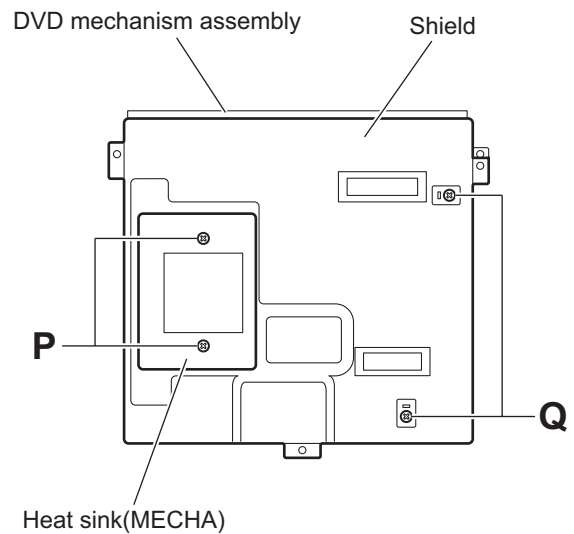

Fig.11
Fig.11

3.1.9 Removing the front board (See Figs. 12 to 14)

- Prior to performing the following procedures, remove the front panel assembly.
 - (1) From the back side of the front panel assembly, remove the six screws **T** attaching the rear cover. (See Fig.12.)
 - (2) Release the ten joints **i** attaching the rear cover to the front panel assembly. (See Fig.13.)
 - (3) Take out the front board from the front panel assembly. (See Fig.14.)

Note:

Do not lose the springs when removing the front board.

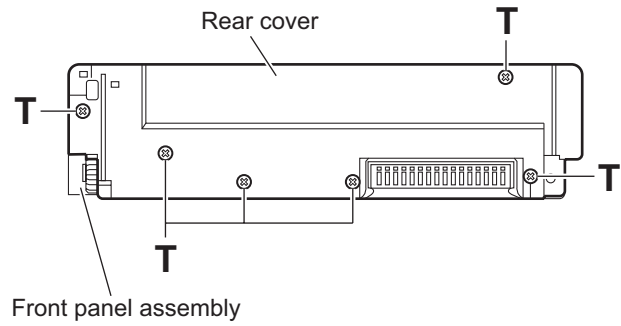

Fig.12

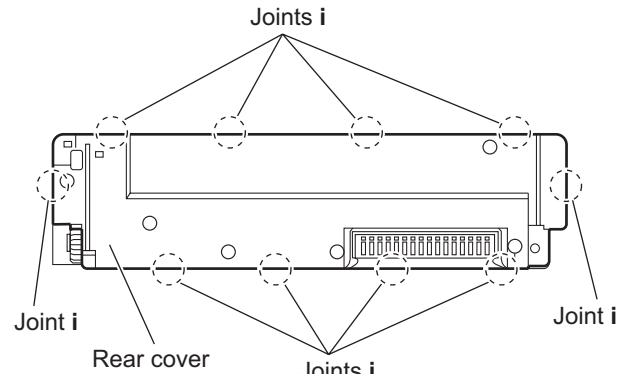

Fig.13

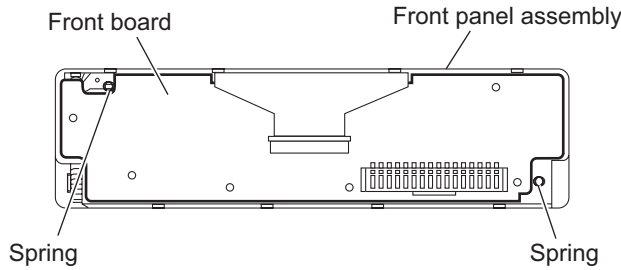

Fig.14

3.2 DVD mechanism assembly

3.2.1 Removing the front end board (See Fig.1)

Caution:

Before disconnecting the flexible wire extending from the DVD pickup, solder the short-circuit point on the flexible wire using a grounding soldering iron. If you do not follow this instruction, the DVD pickup may be damaged.

- (1) Turn over the body, and solder the short-circuit point on the flexible wire extending from the DVD pickup.
- (2) Disconnect the flexible wire from connector **CN10** on the front end board.
- (3) Disconnect the flexible wire from connector **CN201** on the front end board.
- (4) Disconnect the flexible wire from connector **CN202** on the front end board.
- (5) Unsolder two soldering **a** on the front end board and disconnect the wire extending from the feed motor.
- (6) Remove the three screws **A** attaching the front end board.

Caution:

As the flexible wire to be connected to **CN10**, make sure to attach it to the front end board using a double tape.

Caution:

After reassembling, unsolder the short-circuit point.

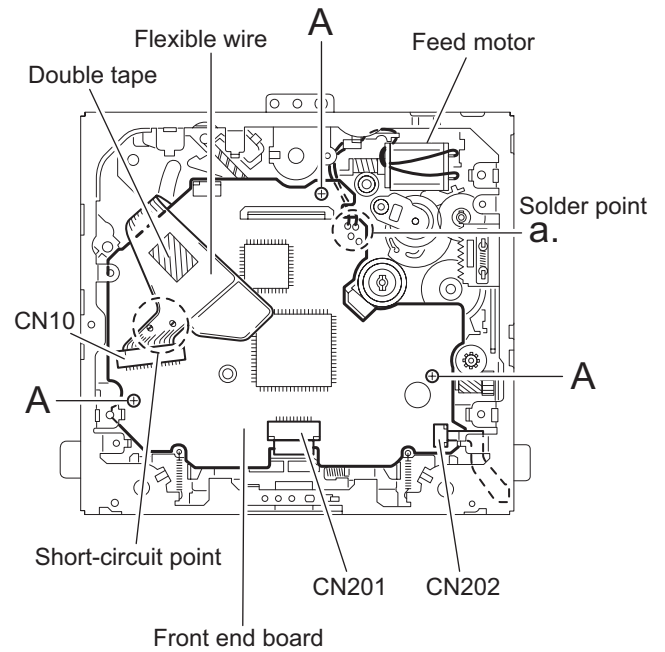

Fig.1

3.2.2 Removing the top cover (See Fig.2)

- (1) Remove the two screws **B** attaching the top cover on the back of the body. Remove the top cover upward.

Reference:

When reassembling, set part **b** of the top cover under the bending part **c** of the chassis frame.

3.2.3 Removing the mechanism section (See Fig.2 ~ 4)

- Prior to performing the following procedure, remove the top cover.
 - (1) Remove the two screws **C** attaching the right and left stoppers on the front side.
 - (2) Remove the two floating springs on the bottom of the body.
 - (3) Move the mechanism section upward and remove from the chassis frame.

The three damper springs come off from the dampers.

Caution:

When reassembling, reattach the damper spring to the damper respectively and insert the three shafts on the bottom of the mechanism to the dampers.

Caution:

Before inserting the shaft to the dampers, apply IPA to the hole of damper.

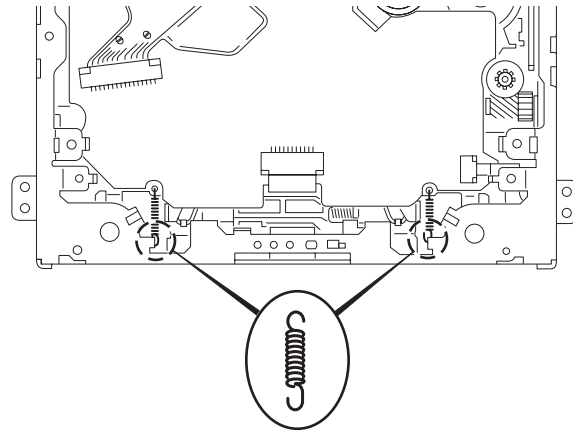

Floating spring
Fig.3

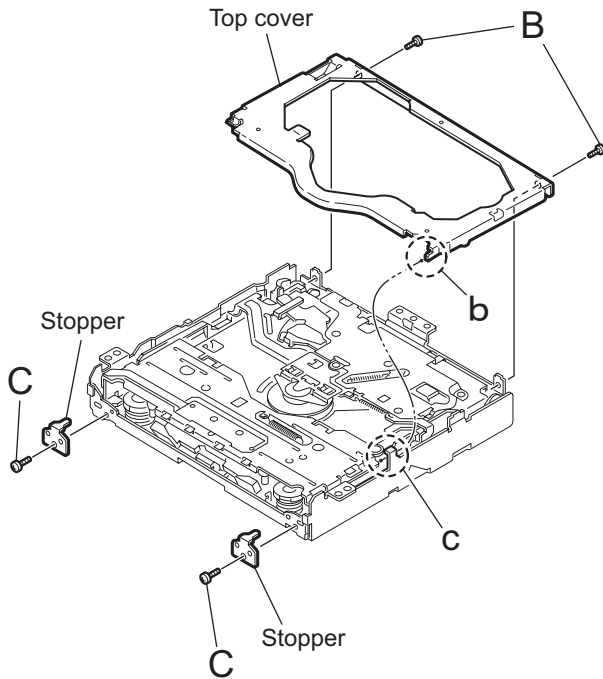

Fig.2

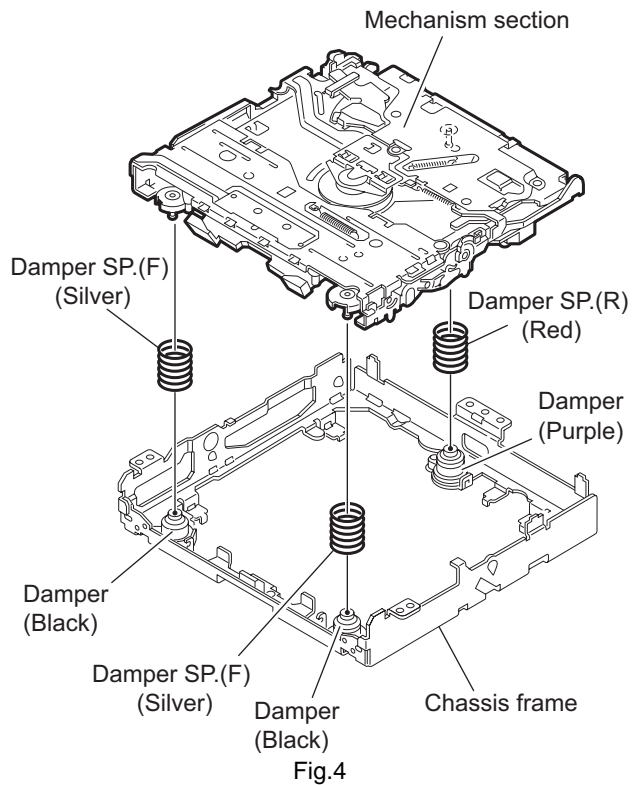

Fig.4

3.2.4 Removing the clamper unit (See Fig.5 ~ 9)

- Prior to performing the following procedure, remove the top cover and the mechanism section.
 - (1) Remove the clamper spring on the bottom of the mechanism section.
 - (2) Release part **d** of the clamper spring from the bending part of the chassis base assembly.
 - (3) Move the clamper unit in the direction of the arrow and turn. Release the two joints **e** and **f**, then remove the clamper unit upward.

3.2.5 Reattaching the clamper unit (See Fig.5 ~ 9)

- (1) Attach the clamper spring to the clamper unit.
- (2) Move the clamper unit to set the side joints **e** and **f** to each boss of the chassis base. Make sure that part **g** is inserted to the notch of the chassis base.
- (3) Move the clamper spring **d** to the outside of the bending part of the chassis base.

Caution:

When reattaching, temporarily hook the end of the clamper spring as shown in the figure to make the work easy.

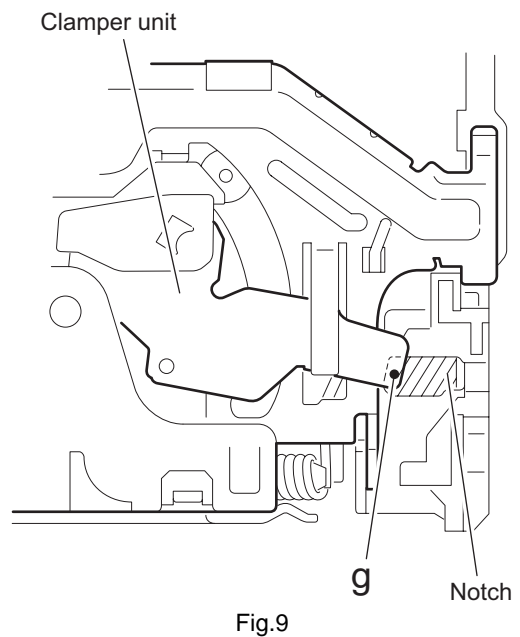
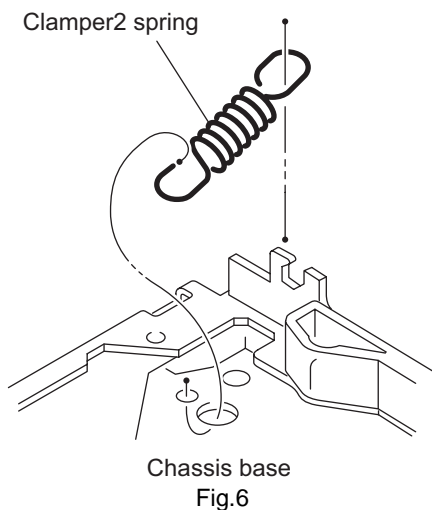
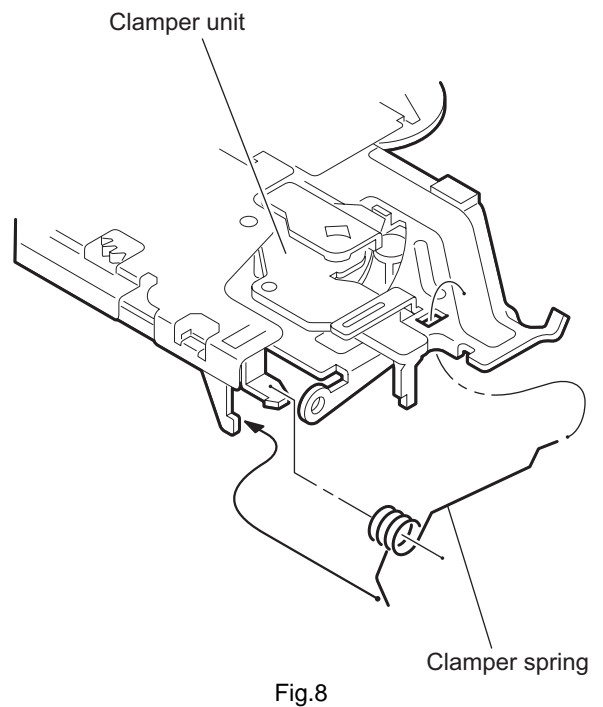
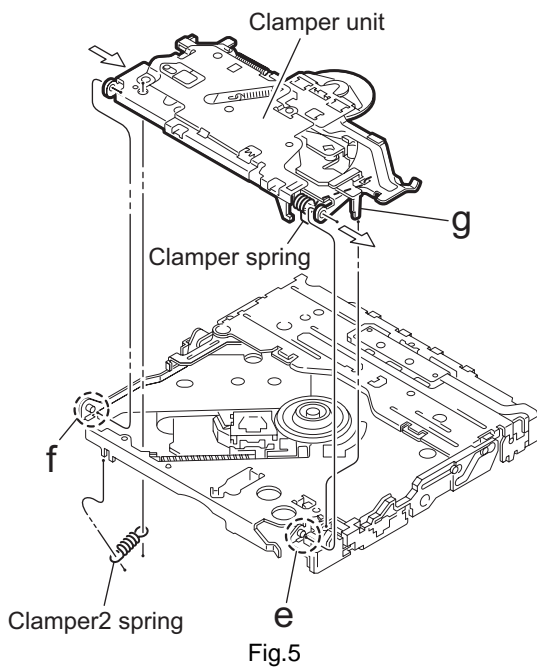
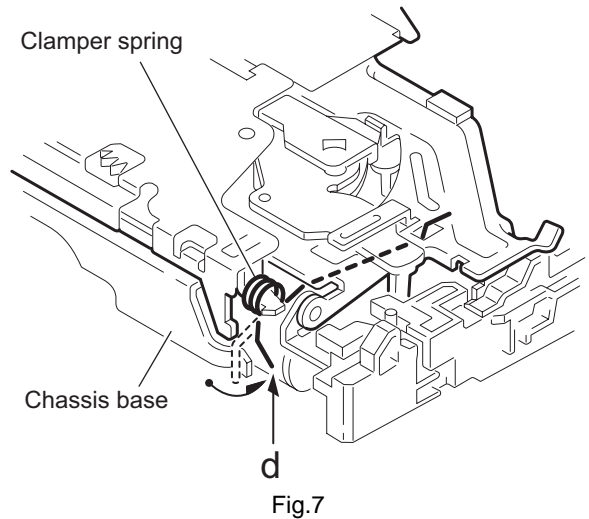

3.2.6 Removing the front unit (See Fig.10 ~ 12)

- Prior to performing the following procedure, remove the top cover and the mechanism section.
 - (1) Disconnect the flexible wire from connector **CN202** on the front end board at the bottom of the body.
 - (2) Remove the screw **D** attaching the front unit on top of the body.
 - (3) Move the front unit toward the front to release joint **h**, and release two joints **i** and **j** on the right side of the chassis base. Then remove the front unit upward.
 - (4) Remove the two screws **E** attaching the switch board.

Reference:

You can remove the switch board only without removing the front unit.

Caution:

When reassembling, attach the flexible wire extending from the switch board using a double tape.

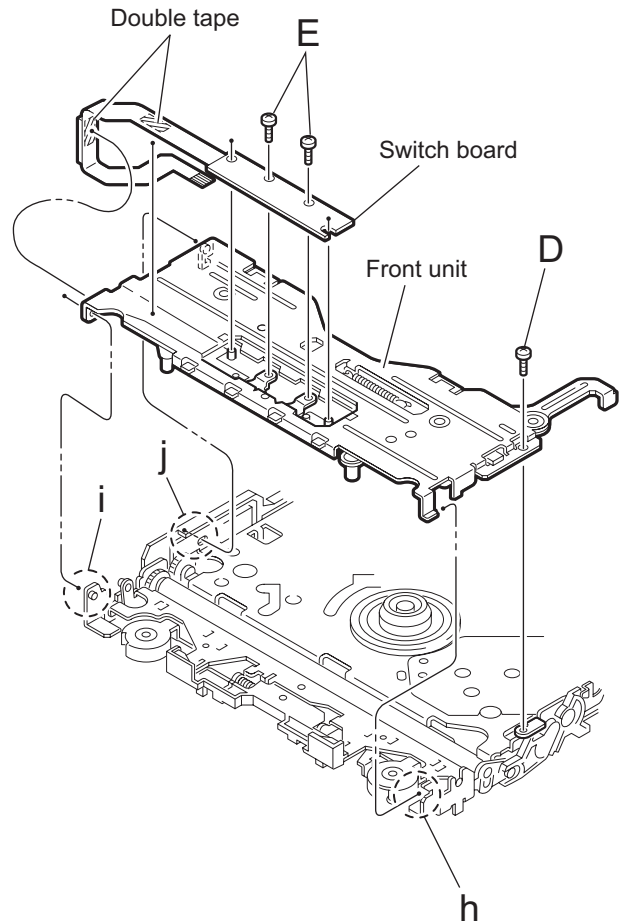
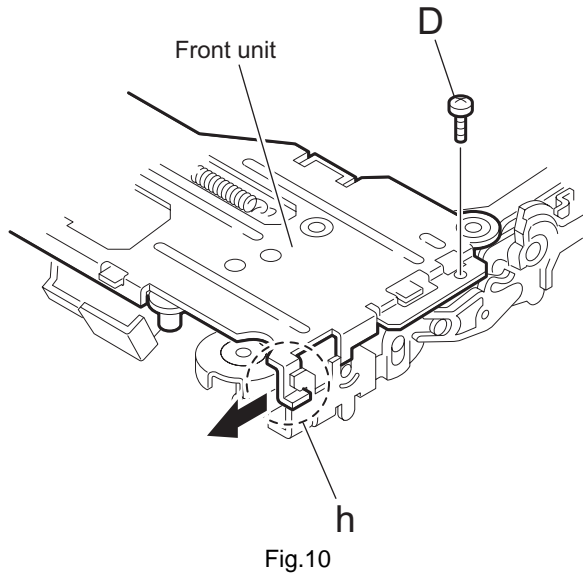

Fig.11

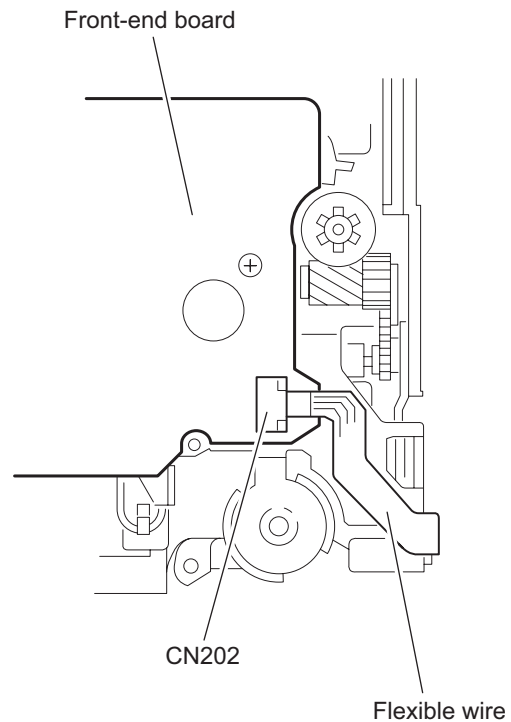

Fig.12

3.2.7 Removing the loading arm S.A. (See Fig.13, 14)

- Prior to performing the following procedure, remove the top cover, the mechanism section and the front unit.
 - (1) From top of the body, move the loading arm S.A. from the front side upward, and release the bosses from the right and left joints **k** and **l** of the chassis base.
 - (2) Release the boss from notch **m** of the connect arm on the right side of the body, and release the boss from notch **n** of the slide cam ass'y on the left side.

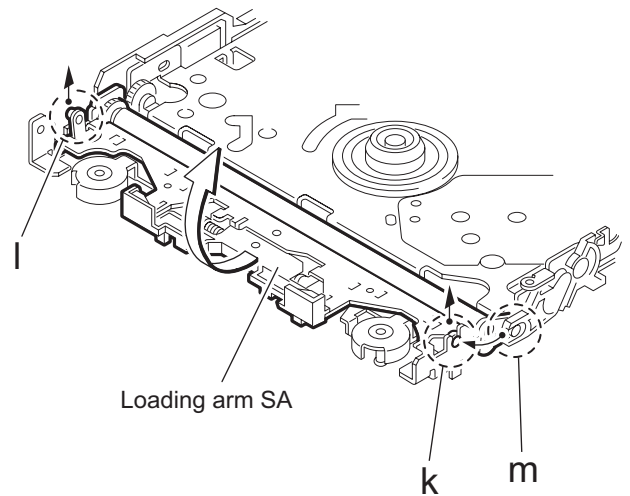

Fig.13

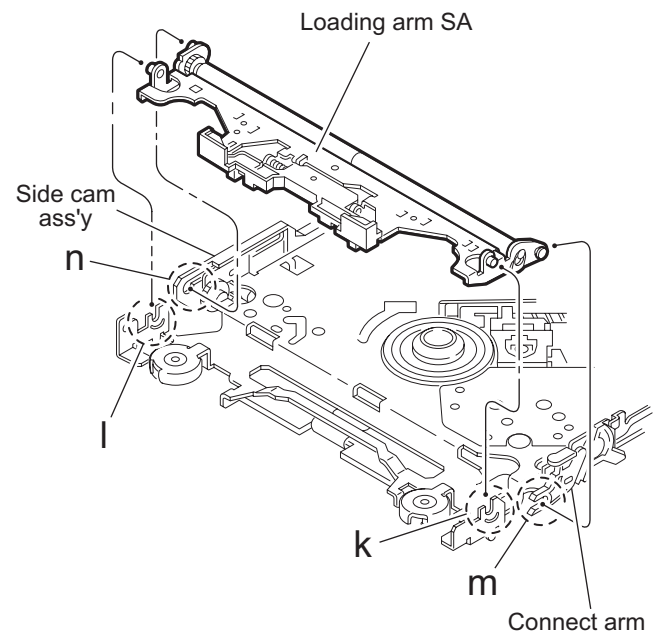

Fig.14

3.2.8 Removing the rod (L)(R)/roller assembly (See Fig.15 ~ 17)

- Prior to performing the following procedure, remove the top cover, the mechanism section, the front unit and the loading arm S.A.

- (1) Release the rod (L) and (R) from the joints at the bottom of the loading arm S.A.
- (2) Remove the roller assembly from the loading A.ass'y.
- (3) Remove the two collars and washer from the roller assembly.

Caution:

After attaching the loading A.ass'y to the roller assembly, attach the rod (L) and (R). Attach the rods to the right and left collars of the roller as shown in Fig.16-1 and Fig.16-2.

When reattaching the rod (L) and (R) to the loading A.ass'y, engage each joint as shown in Fig.15. As joint **n** of the rod (L), let the rod through **n** before reattaching it.

Fig.16-1

Fig.16-2

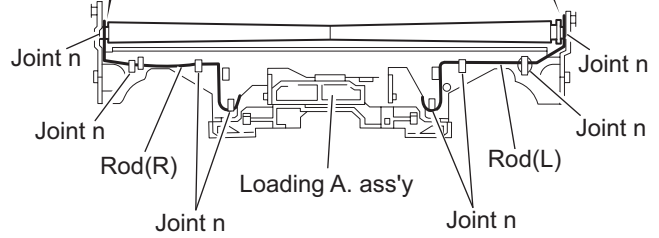
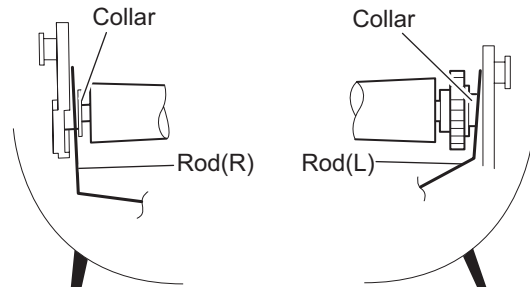

Fig.15

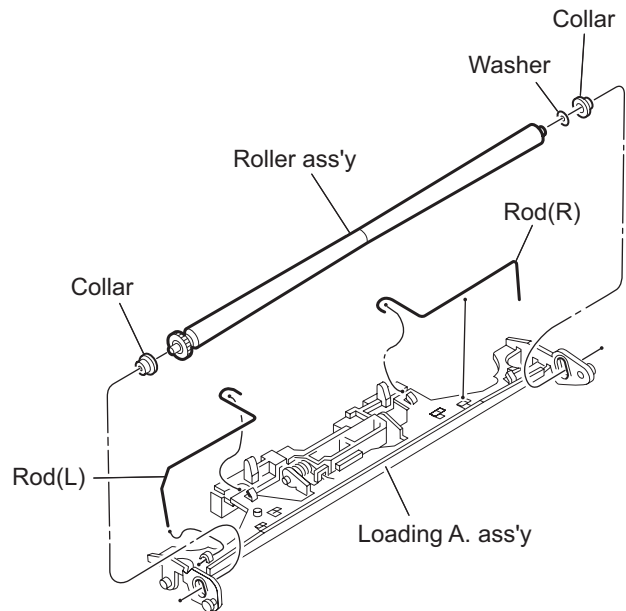

Fig.17

3.2.9 Removing the DVD pickup assembly (See Fig.18 ~ 20)

- Prior to performing the following procedure, remove the front end board.

- (1) At the bottom of the body, turn the feed gear in the direction of the arrow to move the DVD pickup outwards.
- (2) Remove the screw **F** attaching the thrust spring.
- (3) Remove the DVD pickup assembly upward on the L.S. gear side and release from sub shaft at joint **o**. Move the lead screw of the DVD pickup assembly in the direction of the arrow to release from joint **p**.

Caution:

When releasing the lead screw at joint **p**, the L.S.collar comes off at the end of the lead screw. When reassembling, reattach the L.S.collar to the lead screw and engage joint **p**.

Caution:

When reattaching the L.S.collar, reattach it to the point **p** of the lead screw, and to the lod (M). Make sure that the L.S.collar is set on the lod (M) spring.

- (4) Remove the screw **G** attaching the rack spring/ rack plate on the DVD pickup.
- (5) Pull out the lead screw.

Caution:

Perform adjustment after replacing the pickup.

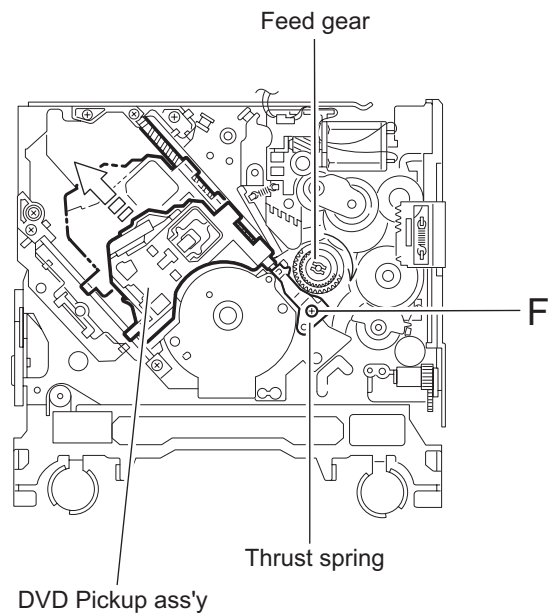

Fig.18

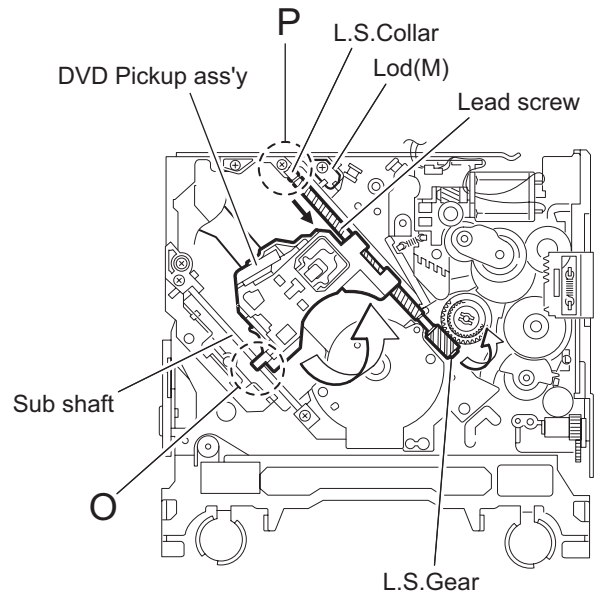

Fig.19

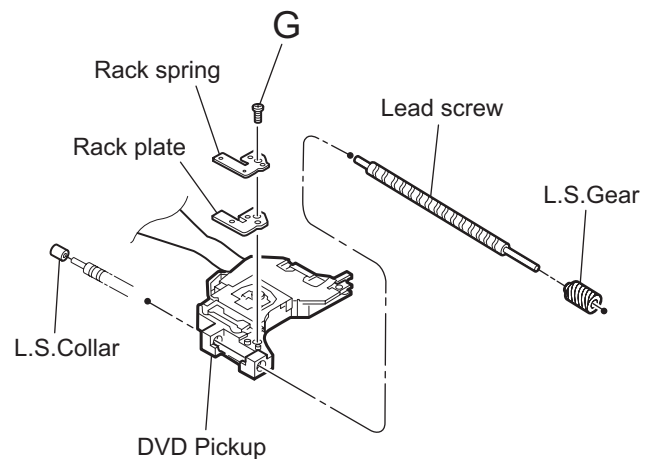

Fig.20

3.2.10 Removing the spindle motor (See Fig.21)

- Prior to performing the following procedure, remove the front end board.
 - (1) Remove the two screws **H** attaching the spindle motor on the bottom of the body.

Caution:

Perform adjustment when reattaching the spindle motor.

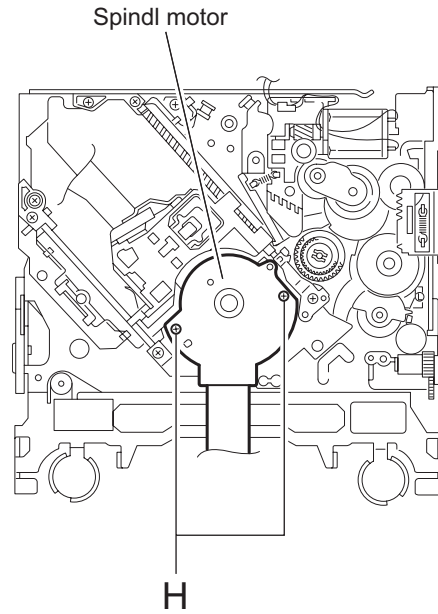

Fig.21

3.2.11 Removing the FL motor S.A. (See Fig.22, 23)

- Prior to performing the following procedure, remove the front end board.
 - (1) Remove the feed TRI.spring on the bottom of the body.
 - (2) Remove the two screws **I** attaching the FL motor SA.
 - (3) Remove the slit washer from the motor H.ass'y and pull out the worm wheel.
 - (4) Remove the two screws **J** attaching the FL motor.

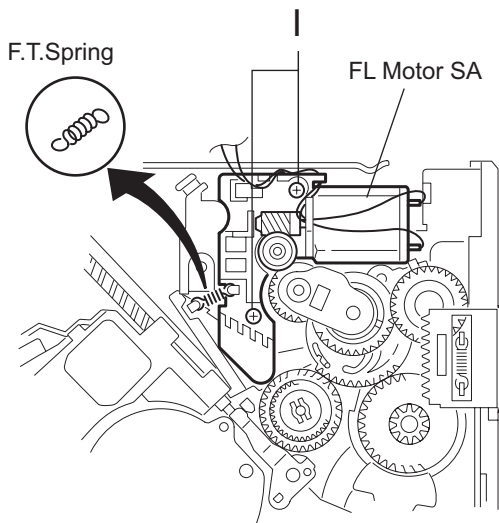

Fig.22

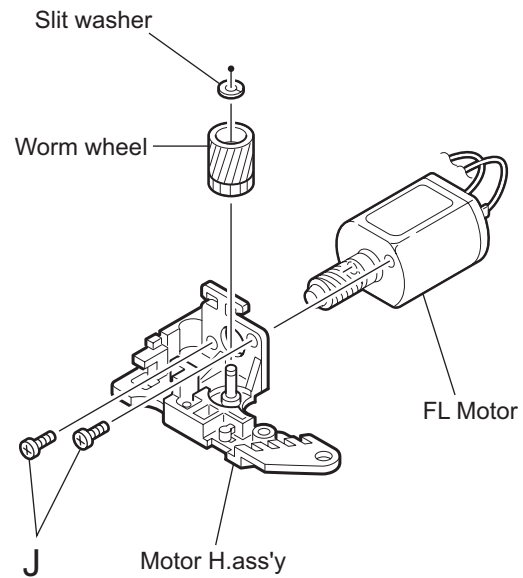

Fig.23

SECTION 4 ADJUSTMENT

4.1 Test instruments required for adjustment

- (1) Digital oscilloscope (100MHz)
- (2) Jitter meter
- (3) Digital tester
- (4) Electric voltmeter
- (5) Tracking offset meter
- (6) Test Disc : VT501 or VT502
- (7) Extension cable for check
- (8) Extension studs and FFC extension cable

4.2 Standard measuring conditions

Power supply voltage : DC14.4V(11V to 16V)
Load impedance : 4 Ω (2 Speakers connection)
Line output : 20k Ω

Caution:

Be sure to attach the heat sink and rear bracket onto the power amplifier IC and regulator IC respectively, before supply the power.

If voltage is applied without attaching these parts, the power amplifier IC and regulator IC will be destroyed by heat.

4.3 For confirmation of the Main board and mechanism movements

■ Connecting diagram 1 of extension cable

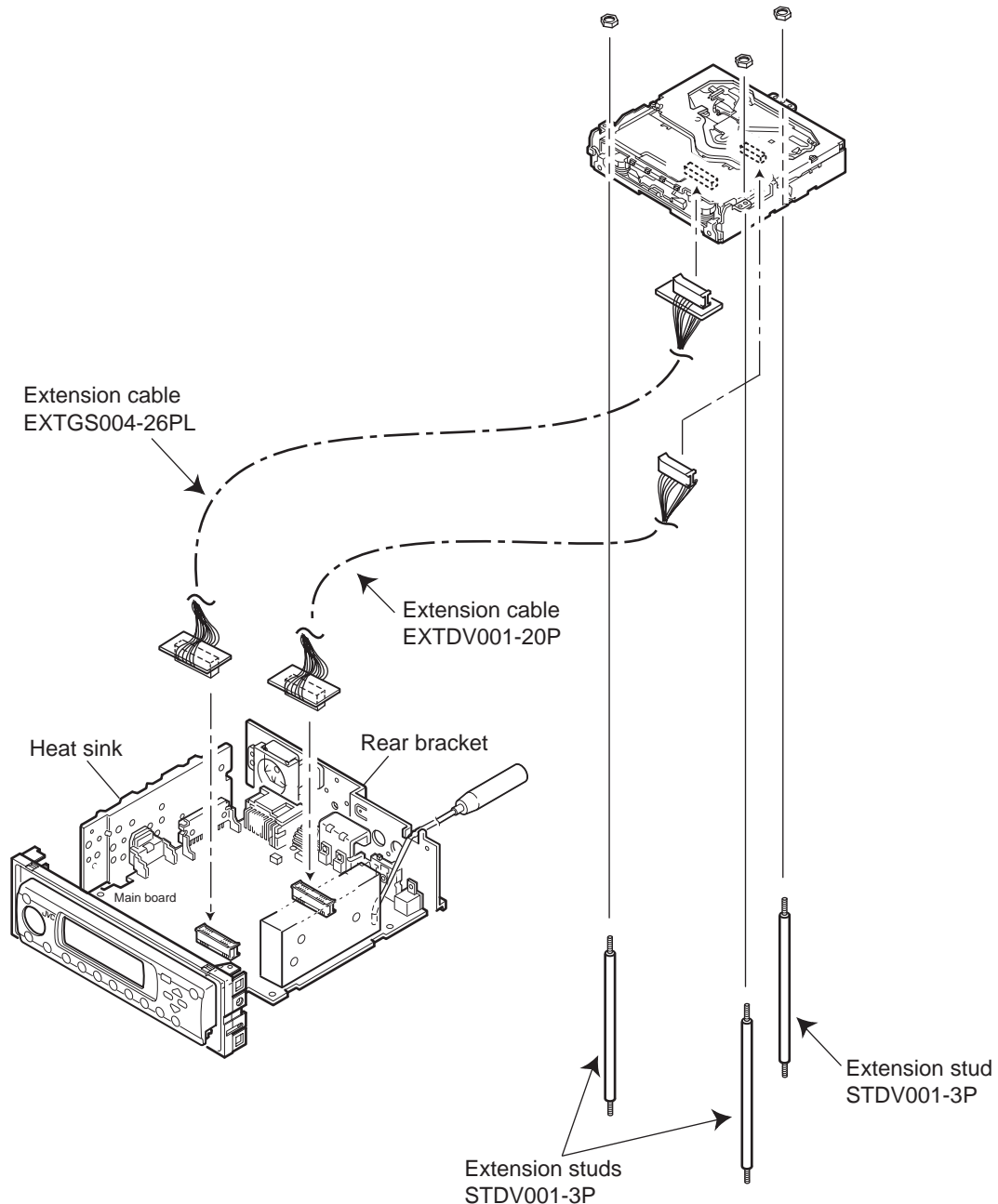

4.4 For the adjustment of the jitter after replacing the pickup

■ Connecting diagram 2 of extension cable

Procedure

Remove the screws attaching the backend board from the mechanism side, connect the backend board to the connectors (26pins/20pins) on the main board.

After attaching the top chassis and front panel assemblies to the main board, attach the extension studs (STDV001-3P) on the top chassis and then attach the mechanism assembly with the nuts.

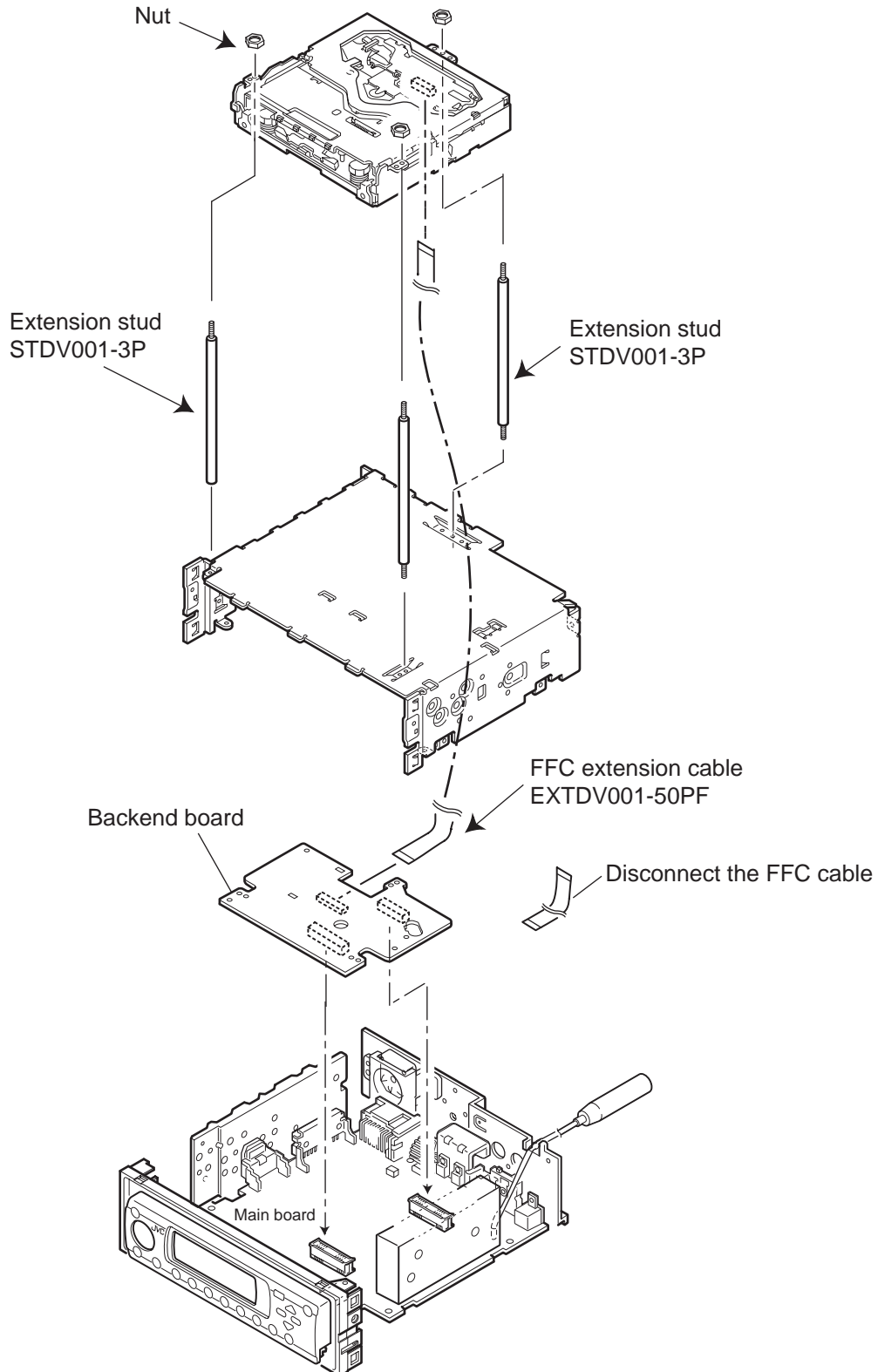

After replacing the pickup, set the unit in the service mode to display a jitter value on the LCD.
Confirm that the jitter value measured with a jitter meter is within 1.2% of the jitter value displayed on the LCD. If it is within 1.2%, then adjustment is not necessary. Please note that a jitter value displayed on the LCD is hex data. Refer to the corresponding decimal notation value using the Jitter Conversion Table and confirm it with the measured value.
Fix the screws "a", "b" and "c" with screw lock paint.

If the measured jitter value is outside the 1.2% tolerance range, perform the following adjustments.

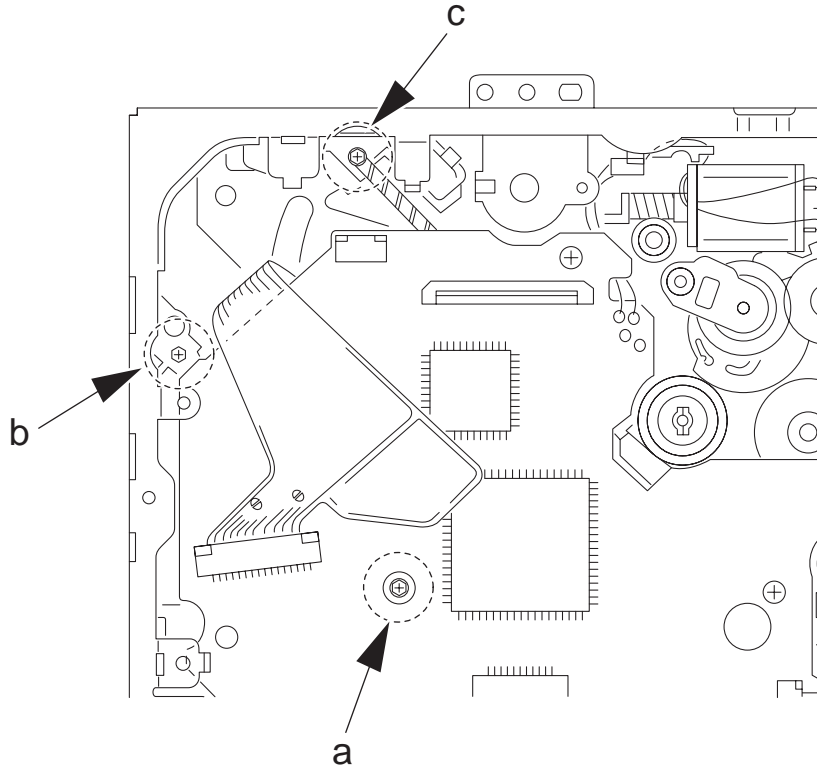

Jitter value adjustment procedure (Pickup horizontal level adjustment relative to the DVD recording surface)
(For the adjustment tool use a 3 mm wrench and not a screwdriver, this procedure will make the adjustment easier.)

3 mm wrench



- (1) Set the unit to the service mode and display a jitter value (hex data) on the LCD.
- (2) Turn each of the screws a, b and c, by a half-turn per step, in the direction that reduces the jitter value in order to minimize it.
(Do not turn a screw more than a half turn at a time, but adjust the screws in the cycle of a → b → c → d → a.)
- (3) After completing the adjustment, secure the screws with screw lock paint.

4.5 Jitter value conversion table

Load the test DVD and set the unit to the service mode. A jitter value converted to the hex value is displayed on the LCD. Refer to the corresponding decimal notation value shown in the following Jitter Conversion Table.

The adjustment is OK if the jitter value measured with a jitter meter is within 1.2% of the jitter value displayed on the LCD.

If the measured jitter value is outside the 1.2% tolerance range, adjust it to minimize the difference between the measured value and the displayed value.

Indicated on the LCD	Jitter value	Indicated on the LCD	Jitter value	Indicated on the LCD	Jitter value	Indicated on the LCD	Jitter value
20A7	4.7	1AA0	7.6	149A	10.5	E93	13.4
2072	4.8	1A6B	7.7	1464	10.6	E5E	13.5
203D	4.9	1A36	7.8	142F	10.7	E28	13.6
2008	5.0	1A01	7.9	13FA	10.8	DF3	13.7
1FD2	5.1	19CC	8.0	13C5	10.9	DBE	13.8
1F9D	5.2	1996	8.1	1390	11.0	D89	13.9
1F68	5.3	1961	8.2	135A	11.1	D54	14.0
1F33	5.4	192C	8.3	1325	11.2	D1E	14.1
1EFE	5.5	18F7	8.4	12F0	11.3	CE9	14.2
1EC8	5.6	18C2	8.5	12BB	11.4	CB4	14.3
1E93	5.7	188C	8.6	1286	11.5	C7F	14.4
1E5E	5.8	1857	8.7	1250	11.6	C4A	14.5
1E29	5.9	1822	8.8	121B	11.7	C14	14.6
1DF4	6.0	17ED	8.9	11E6	11.8	BDF	14.7
1DBE	6.1	17B8	9.0	11B1	11.9	BAA	14.8
1D89	6.2	1782	9.1	117C	12.0	B75	14.9
1D54	6.3	174D	9.2	1146	12.1	B40	15.0
1D1F	6.4	1718	9.3	1111	12.2	B0A	15.1
1CEA	6.5	16E3	9.4	10DC	12.3	AD5	15.2
1CB4	6.6	16AE	9.5	10A7	12.4	AA0	15.3
1C7F	6.7	1678	9.6	1072	12.5	A6B	15.4
1C4A	6.8	1643	9.7	103C	12.6	A36	15.5
1C15	6.9	160E	9.8	1007	12.7	A00	15.6
1BE0	7.0	15D9	9.9	FD2	12.8	9CB	15.7
1BAA	7.1	15A4	10.0	F9D	12.9	996	15.8
1B75	7.2	156E	10.1	F68	13.0	961	15.9
1B40	7.3	1539	10.2	F32	13.1	92C	16.0
1B0B	7.4	1504	10.3	EFD	13.2		
1AD6	7.5	14CF	10.4	EC8	13.3		

SECTION 5 TROUBLE SHOOTING

5.1 Service mode

■ Standard input/output conditions

Power supply voltage : DC14.4V (11V to 16V)
Load impedance : 4 Ω (2 Speakers connection)
Line output : 20k Ω

■ Service mode setting procedure

(The DVD does not need to be loaded before starting the following procedure.)

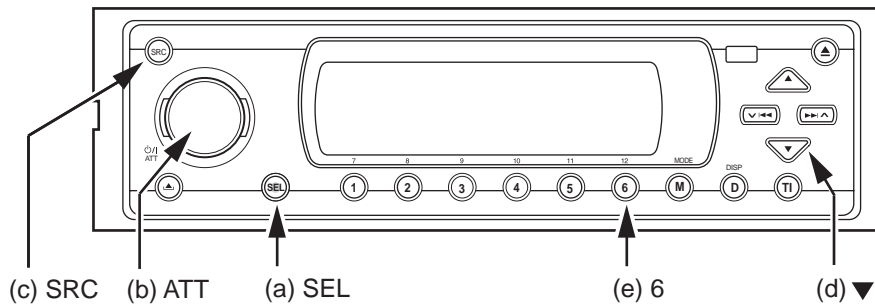

* With the unit turned on, perform the following steps.

1. While holding the button (a), press buttons (b) and (c) together so that the LCD displays the following:

```
AREA/REGION  
VERSION  
RUNNING MODE  
CHECK MODE  
EXPERT MODE
```

2. Press button (b) three times in order to select "CHECK MODE," and then press button (a) so that the LCD displays the following.

```
CHECK MODE  
PRESS A/D KEY
```

Load the test DVD (VT501 or VT502) (this operation is not necessary if the disc has been loaded before starting this procedure), and then press button (e) so that the LCD displays the following.

```
CHECK MODE  
PRESS A/D KEY  
DUDx1 JITTER MODE  
CURRENT: ****  
JITTER: ****
```

When the LCD displays the above, the unit is in the jitter adjustment mode.

**** is a hex number. (Refer to section 4.5, "Jitter Conversion Table.")

■ Operation procedures

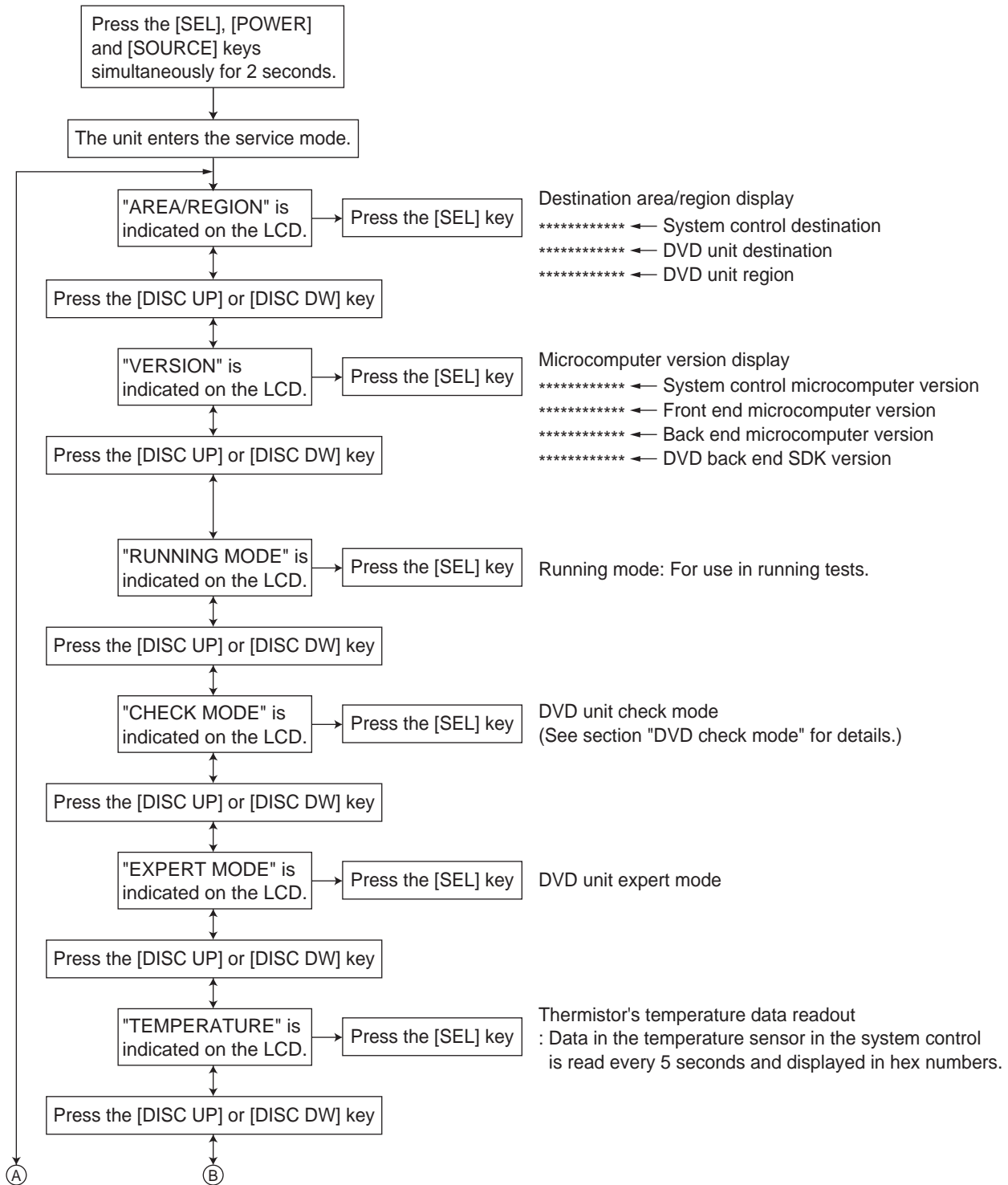

Ⓐ

Ⓑ

"READ ERROR" is indicated on the LCD. → Press the [SEL] key

Read loading and ejection error history : The error history saved in the system control is read and displayed.

TOTAL ERROR zzzz : Total error count.
 Total error count (A figure between 0 and 9999 is displayed. 10000 or more is also displayed as 9999.)

E-n xxxyyy : Latest three error codes.
 Detailed error code
 Error code
 Counter

EOn xxxyyy : First five error codes
 Detailed error code
 Error code
 Counter

Error code (1 byte)

First byte	[01] Eject error [09] Loading error
------------	----------------------------------------

Detailed error codes (2 bytes) * Displayed with loading/ejection errors only.

First byte	Higher 4 bits Route No. (Process of error occurrence) → Refer to charts 1.1 and 1.2. Lower 4 bits Error type [1] Time out [2] Switch status error [3] Swinging error
Second byte	bit7 Disc type (0: 12 cm. 1: 8 cm) bit6,5 Fixed at 0 bit4 SW1 status bit3 SW2 status bit2 SW3 status bit1 SW4 status bit0 REST SW status

(Example) When a switch status error occurs during loading route 3 and the switch status is L/L/H/H/H (00111B = 07H), the error code and detailed error code become: [09 3207].

Route No. (EJECT route No.)	SW1/2/3/4	[Rest SW]	Loading	Eject	Reload		
-	1,1,1,1	[0]	No Disc	No Disc	Disc push in		
1(2)	0,1,1,1	[0]	Disc insert detection	↑	↙		
1(2)	0,0,1,1	[0]	↓	Eject completion		↘	
2(2)	0,0,0,1	[0]		↑	↙	Reload start	
2(2)	0,0,1,1	[0]				↓	↘
2(2)	0,1,1,1	[0]					
3(1)	1,1,1,1	[0]	↓	↑	↓		
3(1)	1,1,1,0	[0]					
3(1)	1,1,1,0	[1]	Load completion	Eject start	Load completion		

Chart 1.1 12cm Disc switch status transition

Route No. (EJECT route No.)	SW1/2/3/4	[Rest SW]	Loading*	Eject	Reload		
-	1,1,1,1	[0]	No Disc	No Disc	Disc push in		
1(2)	0,1,1,1	[0]	Disc insert detection	↑	↙		
1(2)	0,0,1,1	[0]	↓	Eject completion		↘	
2(2)	0,1,1,1	[0]		↑	↙	Reload start	
2(2)	1,1,1,1	[0]				↓	↘
3(1)	1,1,1,1	[0]					
3(1)	1,1,1,0	[0]	↓	↑	↓		
3(1)	1,1,1,0	[1]					
3(1)	1,1,1,0	[1]	Load completion	Eject start	Load completion		

* Transition in the center loading (Similar to 12cm in the side loading)

Chart 1.2 8cm Disc switch status transition

Ⓒ

Ⓓ

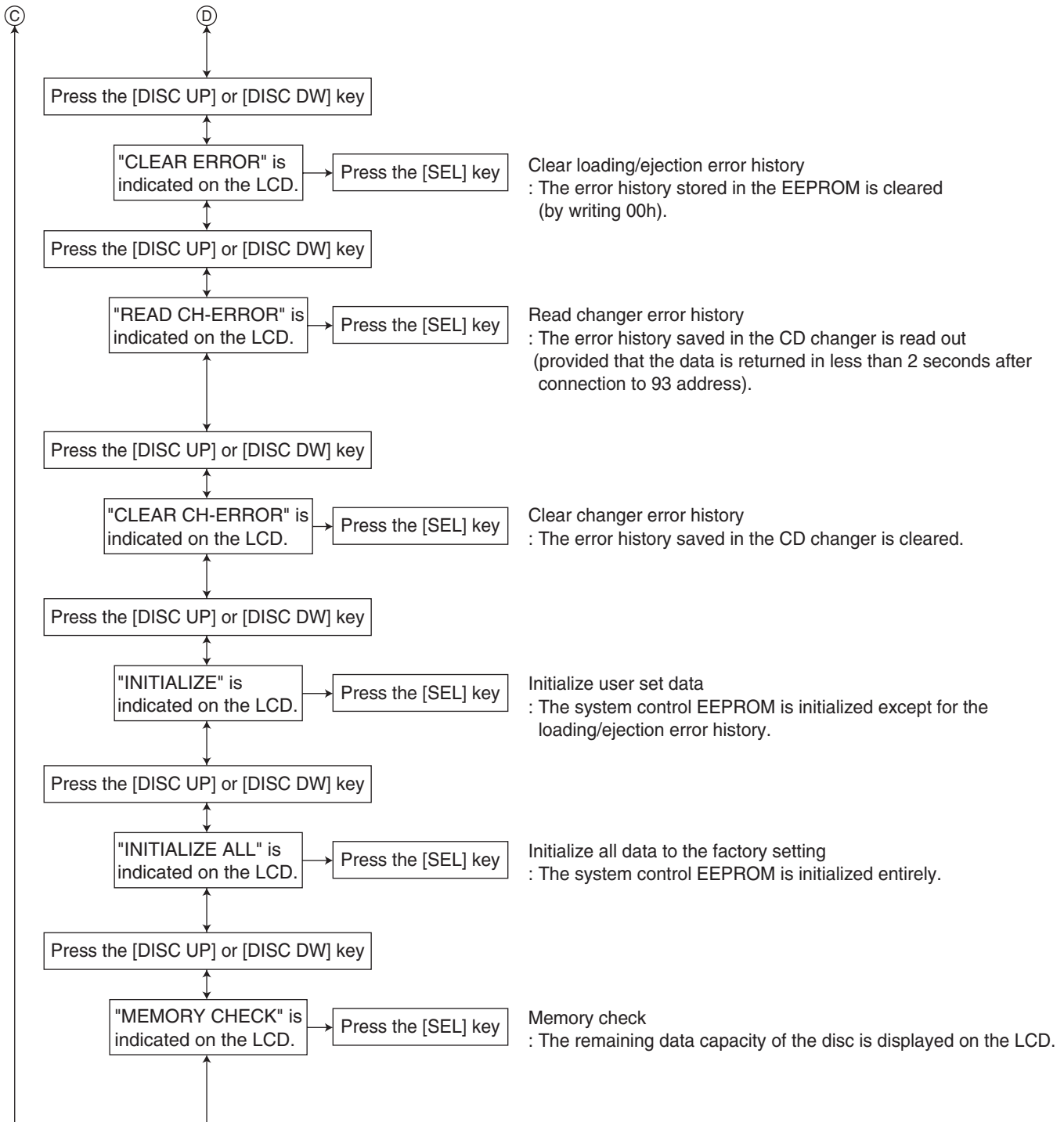

■ DVD unit check mode

- (1) Select "CHECK MODE" in the service mode.
- (2) Various check modes can be displayed according to the key operations.

Check item list

No.	A/D key	DVD unit operation	Indicated on the LCD	Remark
1	[1]	Disc startup and through playback (Playback starts from the start position)	[_CHECK_]	CHECK display remains
2	[2]	Tracking on the outermost position of CD	[OUT_TROFF]	For EF phase error
3	[3]	Tracking on the innermost position of CD	[IN_TROFF]	For EF phase error
4	[4]	CD_LD lights and laser current is displayed	[****_####]	**** : Laser current value #### : Jitter value
5	[5]	DVD_LD lights and laser current is displayed	[****_####]	**** : Laser current value #### : Jitter value
6	[6]	DVD x1 jitter measuring mode (for use in mechanism adjustment)	[****_####]	**** : Laser current value #### : Jitter value
7	[F-SKIP]	Contents of EEPROM used by mechanism (0x00 - 0xFF displayed (FWD))	[****_####]	**** : EEPROM address #### : EEPROM contents
8	[B-SKIP]	Contents of EEPROM used by mechanism (0x00 - 0xFF displayed (BWD))	[****_####]	**** : EEPROM address #### : EEPROM contents
9	[SRC]	Initialization of EEPROM contents used by the mechanism	[_____]	No display
10	[MODE]	Search & jitter measurement of the specified position of DVD-SL	[****_####]	**** : 0x00-0x02 (Position measured with VT-502) #### : Jitter value
11	[DISP]	Search & jitter measurement of the specified position of opposite disc of the DVD-DL	[****_####]	**** : 0x00-0x06 (Position measured with VT-501) #### : Jitter value
12	[TI]	Search & jitter measurement of the specified position of parallel disc of DVD-DL	[****_####]	**** : 0x00-0x06 (Position measured with VT-501) #### : Jitter value
13	[DISC UP]	Disc playback	[****_####]	**** : Laser current value #### : Jitter value
14	[DISC DOWN]	Disc stopped & LD-OFF	[_CHECK_]	CHECK display remains
15	When disc is opened or [TEST8]	OPEN	[_CHECK_]	CHECK display remains
16	When disc is closed	CLOSE	[_CHECK_]	CHECK display remains

(Cautions for Operation)

- Press key [1] of No. 1 before an item in which the No. 2 or 3 key is pressed.
- Press key [6] of No. 6 before an item in which one of the No. 10, 11 or 12 keys is pressed.
- The check mode can be exited either by pressing the [POWER] key or by resetting the unit.

5.2 Firm ware upgrade [Use remote controller RM-RK210]

(1) Upgrade

- Video out terminal connect to TV monitor.
- Insert upgrade disc (written firm ware) to set.
- "firmware upgrade DISC... press UP" on TV monitor.
- Push "UP" button on remote controller.
- "upgrade complete: rebooting in* "
- Wait until this indication on TV monitor up side.
- Then push "EJECT" button.
- Later automatically DISC eject.
(It takes time for a long than usual eject.)

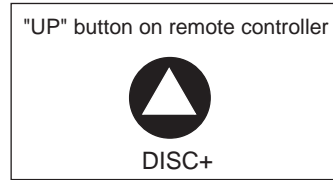

(2) Complete work

- Push 3 button at same time for a while "SEL" "SRC" "POWER" (keep thgis order).
- Push ▲ button indicate "INITIALIZE" on LCD.
- Then push "SEL" button. Indicate "COMPLETED" on LCD: OK

(3) Power OFF

- Push power button → Power is OFF.

5.3 Shipping position (Final process)

(1) Confirm firm ware

- Push 3 button at same time for a while "SEL" "SRC" "POWER" (keep this order).
- Indicate on LCD "AREA/REGION" → Push "SEL" button.
- Confirm on LCD "B/E AREA" is "U" "A".
- Next push "UP" button.
- Confirm on LCD "B/E-VER" is "CORRECT NUMBER" (Refer to W/STD VDG3163 10 14/)

ERSION	B/E-AREA	B/E-VER
U	U	REFER FA W/STD
A	A	REFER FA W/STD

Reference

VERSION	B/E-AREA	B/E-VER
J	J	REFER FA W/STD
E	E	REFER FA W/STD
U	U	REFER FA W/STD
A	A	REFER FA W/STD
DOM	DOM	REFER FA W/STD



JVC

VICTOR COMPANY OF JAPAN, LIMITED

AV & MULTIMEDIA COMPANY MOBILE ENTERTAINMENT CATEGORY 10-1,1chome,Ohwatari-machi,Maebashi-city,371-8543,Japan

(No.49879)



Printed in Japan
WPC